

01 Completely peel back the lid of the first blister pack.

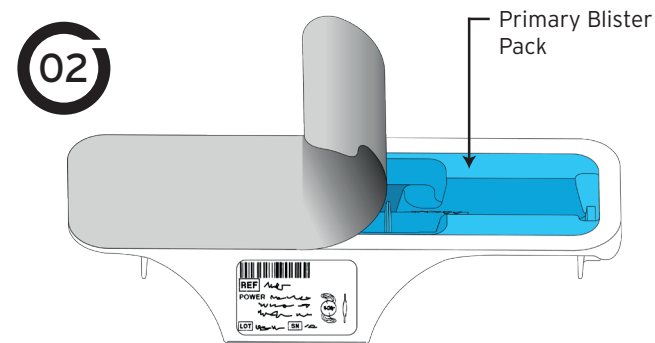

02 Carefully peel back the lid half way down the second blister pack.

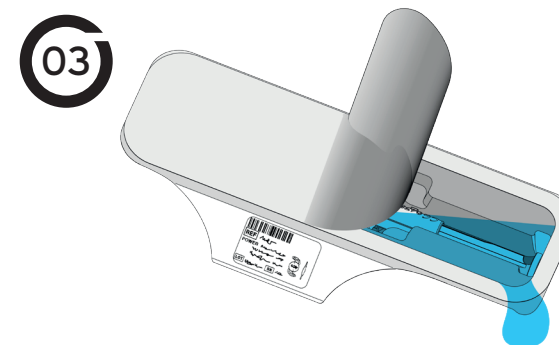

03 Carefully drain the saline from the blister tray and peel off remaining lid. **Do not remove the injector from the blister tray.** For hydrophilic lenses, do not wait more than 3 minutes before adding OVD - dehydration risk.

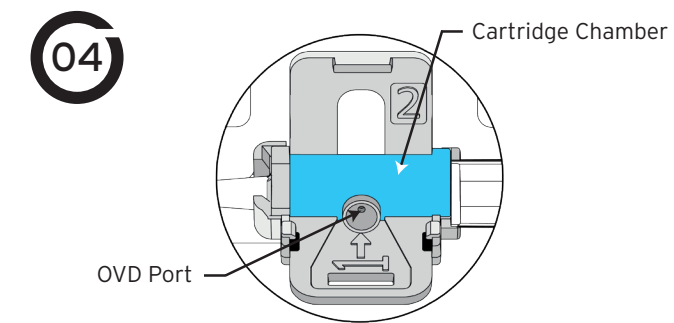

04 Insert the viscoelastic cannula into the opening marked with an arrow on the cartridge and apply sufficient OVD to completely fill the cartridge. **NOTE:** Rayner's patented "Lock & Roll" injector technology uses the mechanical force of OVD inserted into the indicated port to move the IOL from 'storage' to 'roll ready' position at the bottom of the cartridge; do not add OVD directly via the nozzle tip.

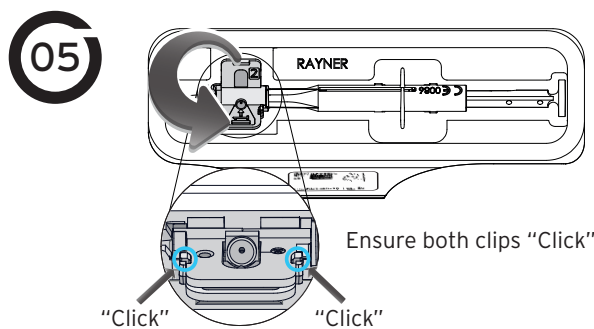

05 Keep the injector in the tray and close the cartridge firmly together by pushing the moving half of the cartridge (labelled 2) against the fixed half until you hear it click closed. **Check both clips have "clicked" shut and secured the cartridge.**

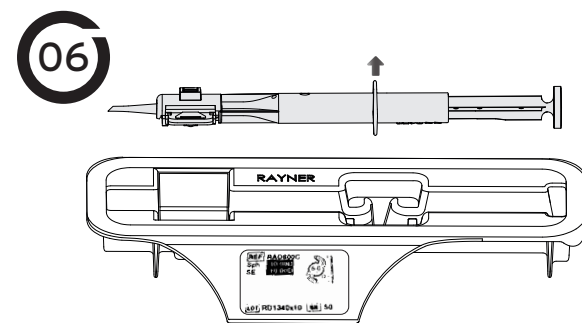

06 Gently lift out the injector from the tray.

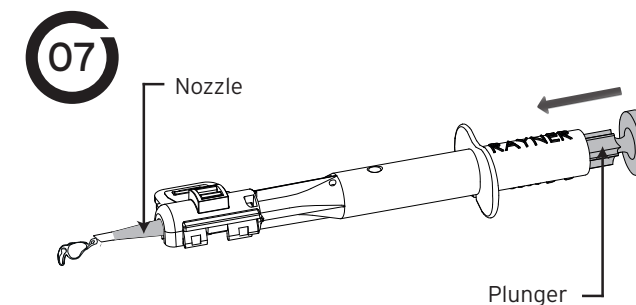

07 Press the plunger in a slow and controlled manner. If excessive resistance is felt this could indicate a blockage; discontinue use of the product and return the product and all packaging to Rayner. In the case of IOL rotation during ejection from the nozzle, gently rotate the injector in the opposite direction to counteract any movement.

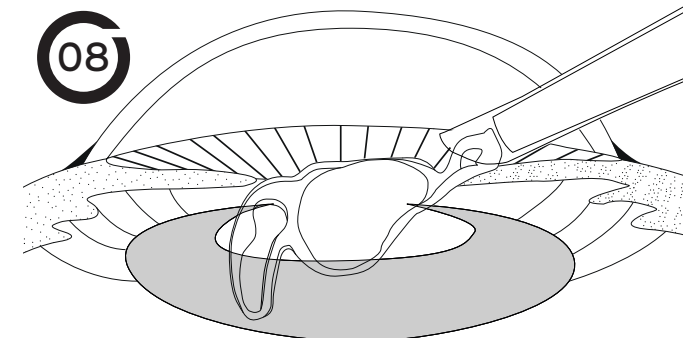

08 Stop depressing the plunger when the IOL exits the nozzle. Discard the injector after use. Following implantation, irrigate/ aspirate to eliminate any OVD residues from the eye, especially behind the IOL.

